

# RWM 100 Baling Press

## Technical Specification

Medium-sized balers are great for businesses handling a notable amount of dry recyclable waste per week/month. But it is still difficult knowing which machine to invest in.

With a cycle time of only 28 seconds and an impressive press force, this new RWM 100 is fast becoming a popular choice. Users will benefit from a tidier and safer site, a fulfilled environmental conscience and significant cost savings by avoiding expensive lifts.

- Handles **cardboard, paper and plastic** with no fuss
- Produces neat bales of up to **10kg**
- **Hydraulically operated** with ergonomic design
- Suitable for both **indoor and outdoor use**
- **Most affordable** mid-sized baler
- Requires only a **low power supply**
- **CE approved**
- Available to **buy or rent**
- Full operator **training provided**
- 12 month **parts and labour warranty**
- Popular with businesses ranging from hotels to manufacturers



**Contact Us**

**0115 896 5460**

# RWM 100 Baling Press

## Technical Specification

Press Force	6 Tonnes
Loading Aperture (H x W x D)	466 x 9800 x 800mm
Bale Weight	up to 100Kg
Bale Dimensions (H x W x D)	847 x 980 x 800mm
Cycle Time	28 seconds
Noise	68 decibels
Machine Weight	7801 Kg
Power Supply (kW-V-Hz)	13amp 1.51kW-240V-50Hz
Overall Dimensions (H x W x D)	2371 x 1388 x 1046mm

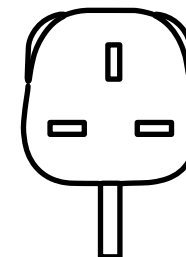
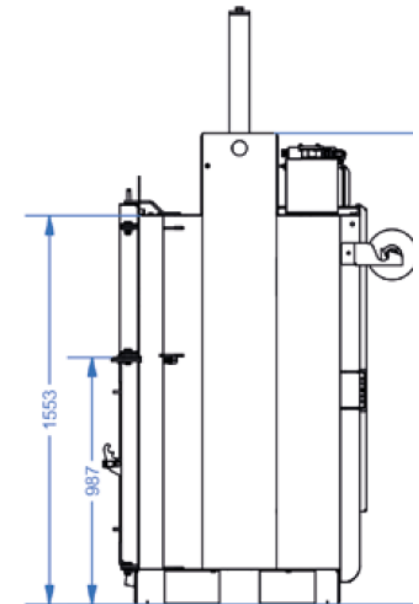
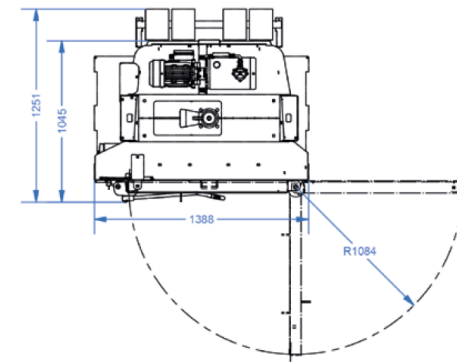
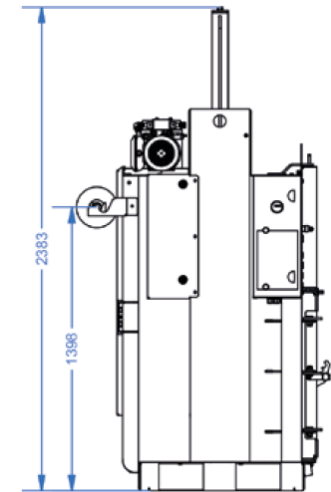
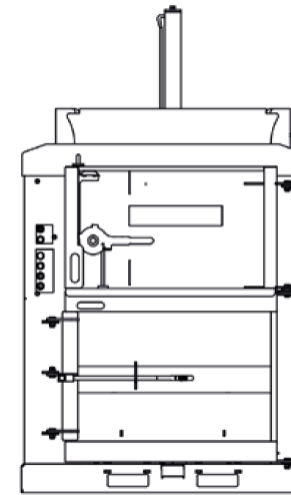

**Operating Voltage** – 220 - 240v.

**Frequency** – 50hz.

**Connector plug fitted** – 13amp single phase, standard three pin plug. MCB (Minature circuit breaker) if fitted – Cat C or above